

REVISIONS		
ISS	ZONE	DESCRIPTION\PER REQUEST\DATE

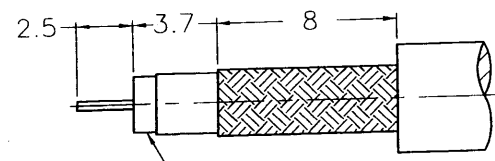

REMOVE FOIL 1mm MIN.  
(去除箔膜1mm以上)

RECOMMENDED  
CABLE STRIPPING DIM'S  
(建議剝線尺寸)

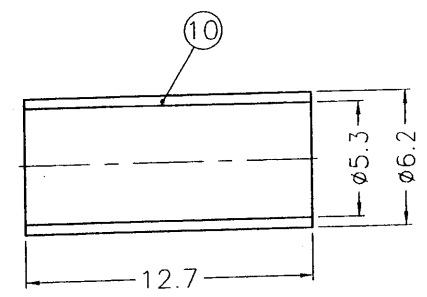
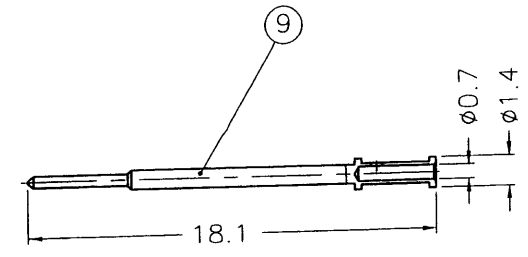
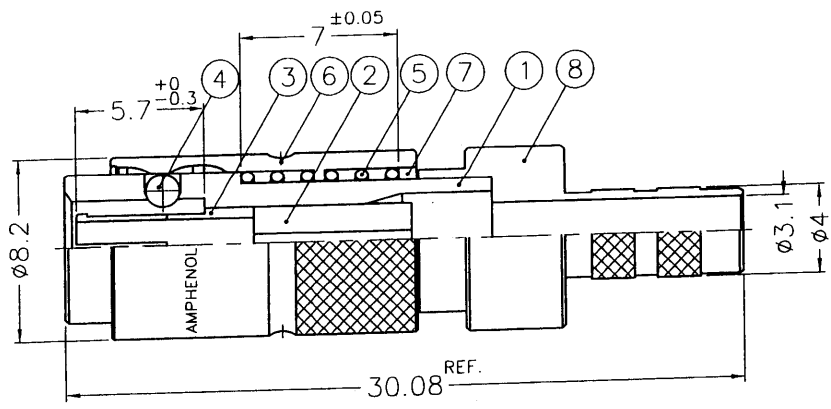

- NOTES: FINISH (PLATING THICKNESS IN MICRO-INCHES)
- BRASS PER QQ-B-626
  - BERYLLIUM COPPER
  - NICKEL PL. 100 MIN. THICK OVER COPPER STRIKE
  - NICKEL PL. (100 MIN./160 MAX.) THICK OVER COPPER PL. (100 MIN./160 MAX.) THICK
  - GOLD PL. (4 MIN./8 MAX.) THICK OVER NICKEL PL. (80 MIN./120 MAX.) THICK
  - PTFE (TEFLON MIL-P-19468)
  - JIS H 3250, C 2600

- CRIMPED FERRULE  
HEX. CRIMP SIZE .213"
- CONTACT PIN TO SOLDER

NO.	DESCRIPTION	MATERIAL	FINISH	Q'TY	DRAWING NO.
10	FERRULE			1	FR00AAC74A
9	CONTACT PIN			1	CP10ACH01A
8	BARREL			1	BR00AKK02A
7	RING			1	4M-852-01
6	OUTER BODY			1	3D-601-03-C
5	SPRING	STAINLESS STEEL	NATURAL	2	4M-170-02
4	BALL	STAINLESS STEEL	NATURAL	3	4M-169-01
3	OUT CONTACT			1	4G-980-01
2	INSULATOR			1	NS10AAA01A
1	BODY			1	3D-600-48

DIMENSIONS ARE IN MILLIMETERS

UNLESS OTHERWISE SPECIFIED TOLERANCES

0.5-6 = ±0.2  
6-30 = ±0.4  
30-120 = ±0.6  
120-315 = ±1  
315-1000 = ±1.6  
1000-2000 = ±2.4

PART NO.	
APPROVED	DATE 01-19-05'
CHECKED	DATE 01-19-05'
DRAWN	DATE 01-19-05'
FILE NO. F.123\1111L2\FLEX-5-75\N5GT5GSZ	

**Amphenol**  
Danbury,CT,USA-Tainan,Taiwan-Shenzhen,China

TITLE  
1.0/2.3 PUSH-PULL CRIMP PLUG (75 ohm)

DRAWING NO.  
1231111L2-N/5GT5G-FLEX-5-75

ITEM NO.  
101111AAY51LD7F

B

A

F

E

D

C

I